

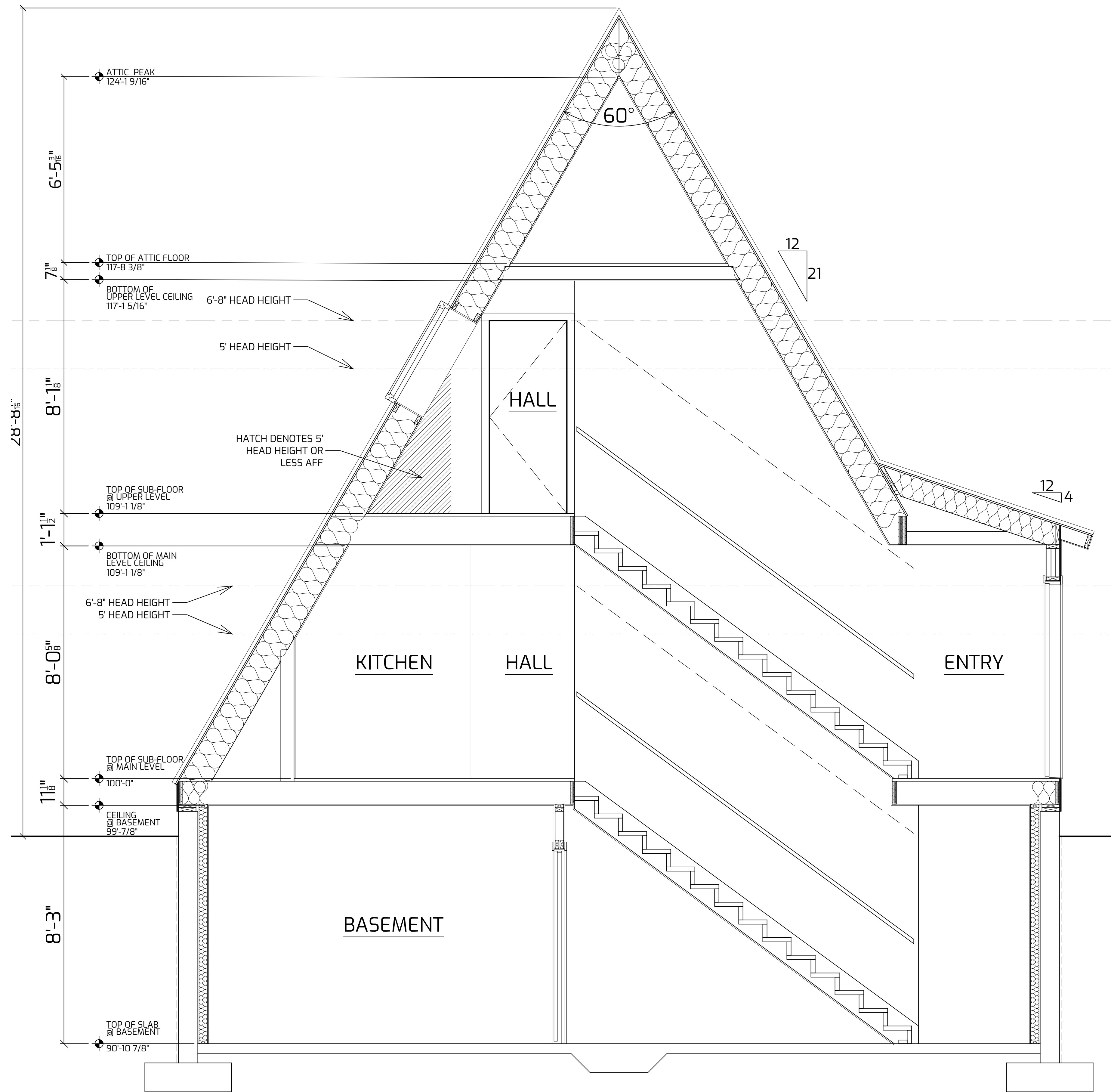

**BUILDING CROSS SECTION**

NTS



**REAR ELEVATION**

NTS

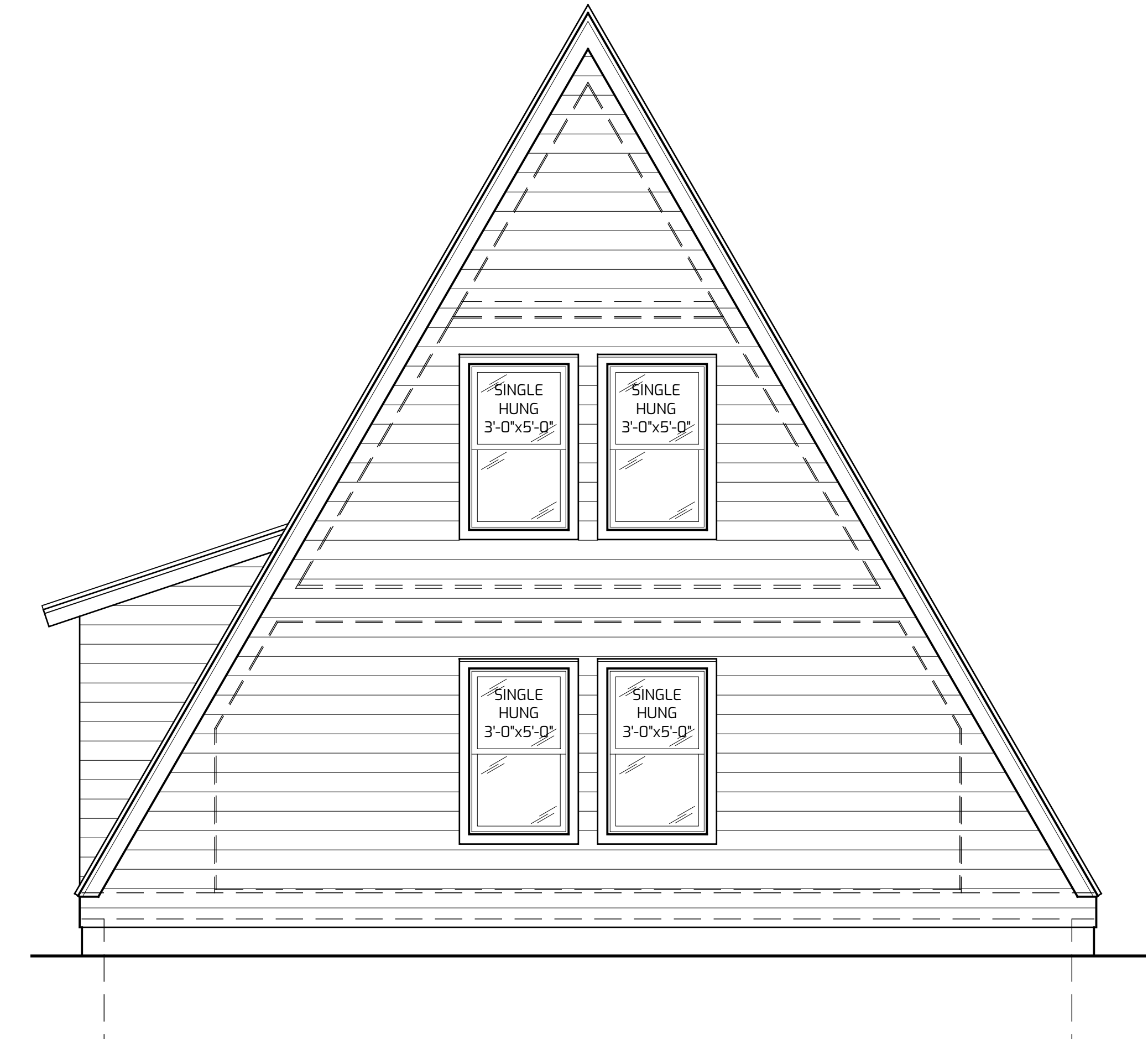

**FRONT ELEVATION**

NTS



THE GRAPHIC MATERIAL AND DESIGN ARE THE PROPERTY OF AVRAME U.S.A. REPRODUCTION OR REUSE OF THE MATERIAL AND DESIGN CONTAINED HEREIN IS PROHIBITED WITHOUT THE WRITTEN CONSENT OF AVRAME U.S.A. VIOLATORS WILL BE PROSECUTED TO THE FULLEST EXTENT OF THE LAW. COPYRIGHT AVRAME U.S.A. ALL RIGHTS RESERVED.

**TRIO 120 STRAIGHT STAIR W/ BASEMENT**

**SQUARE FOOTAGE**

MAIN LEVEL: 901 SQ.FT

UPPER LEVEL: 457 SQ.FT

BASEMENT: 1,077 SQ.FT

TOTAL: 2,435 SQ.FT

DATE 01/2022

**TRIO 120 SPIRAL STAIR W/ BASEMENT**

**SQUARE FOOTAGE**

MAIN LEVEL: 901 SQ.FT  
UPPER LEVEL: 457 SQ.FT  
BASEMENT: 1,077 SQ.FT  
TOTAL: 2,435 SQ.FT

DATE 01/2022

**UPPER LEVEL FLOOR PLAN**  
SEE GRID FOR SCALE

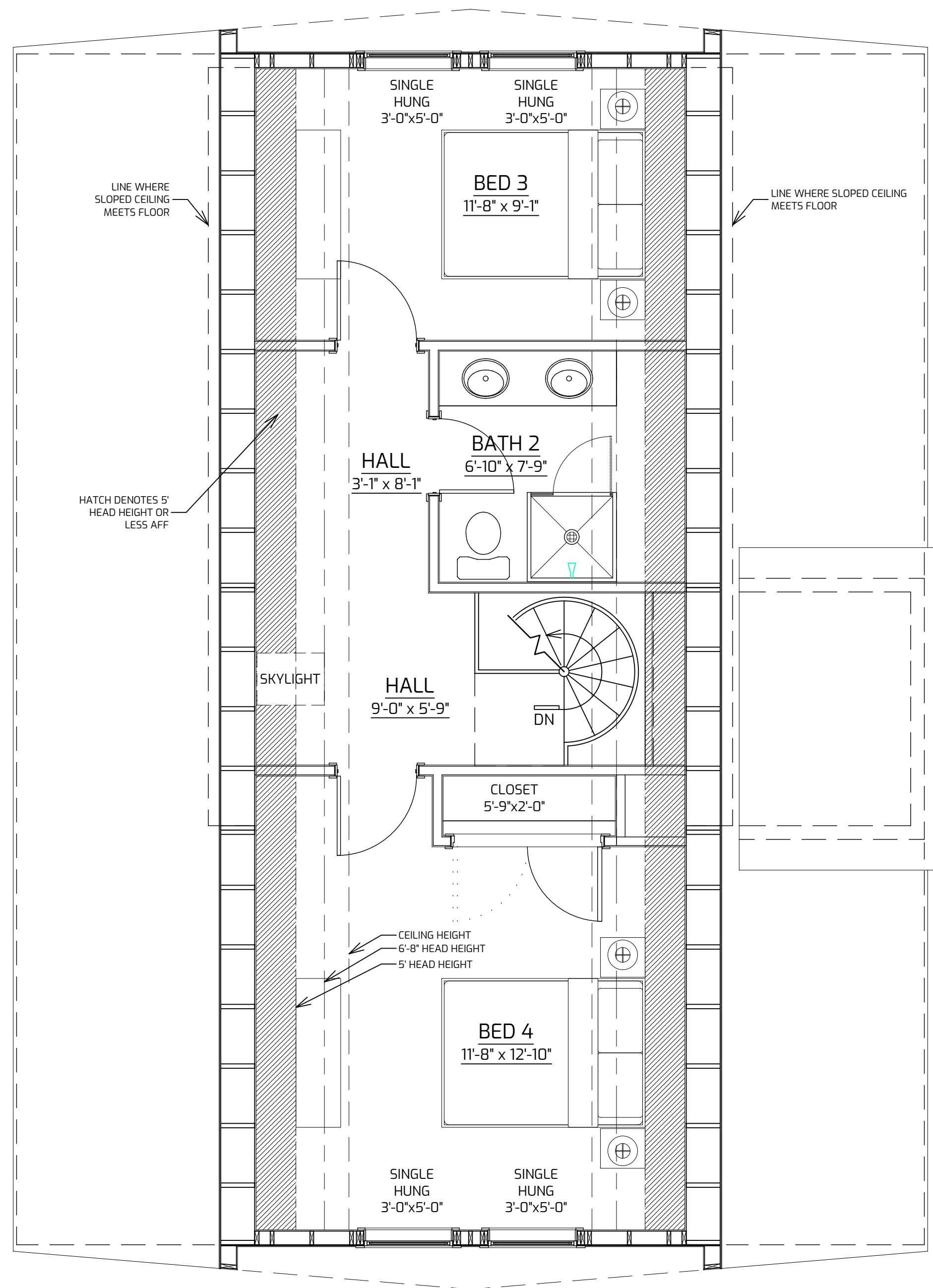

**MAIN LEVEL FLOOR PLAN**  
SEE GRID FOR SCALE

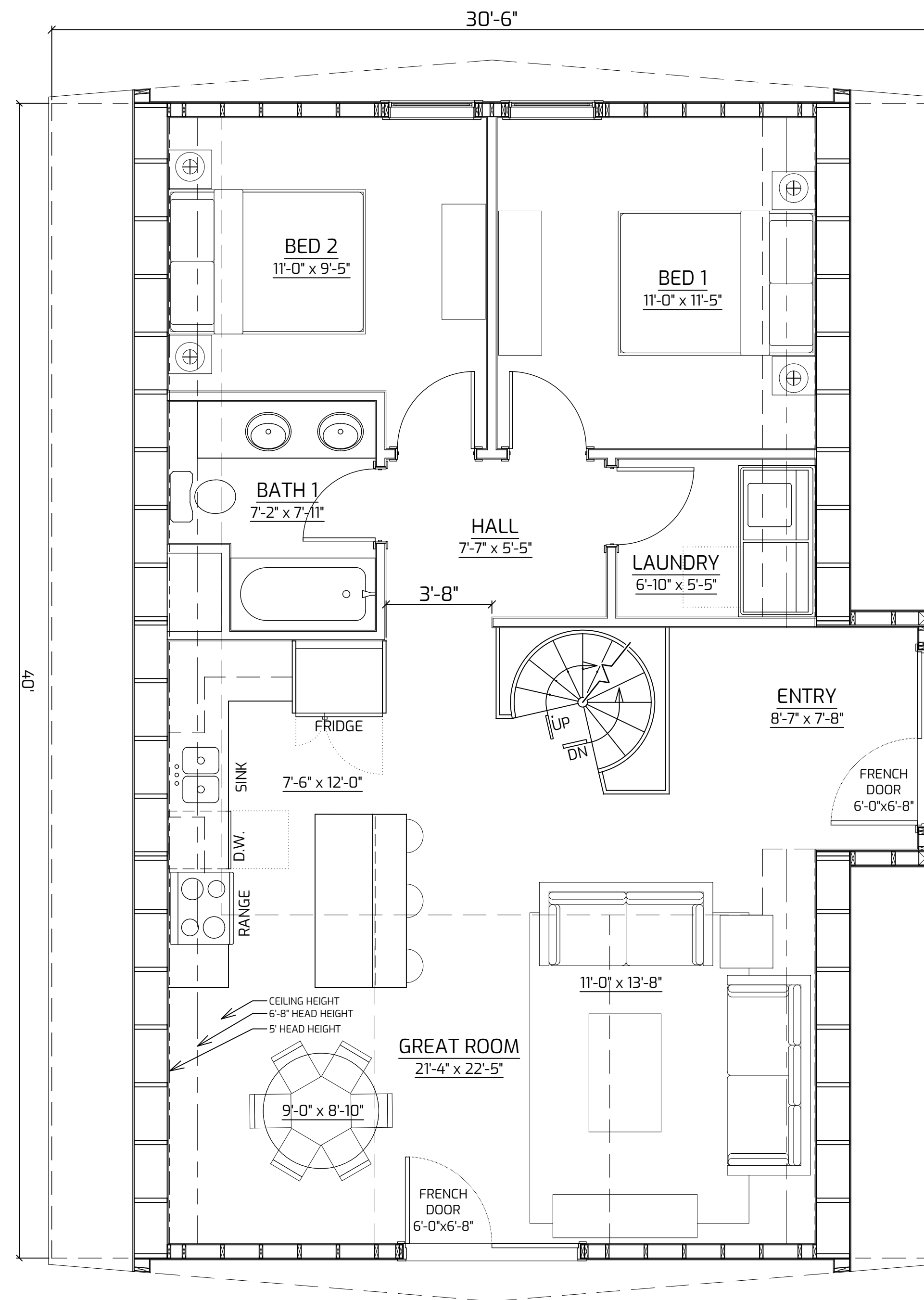

**BASEMENT LEVEL FLOOR PLAN**  
SEE GRID FOR SCALE

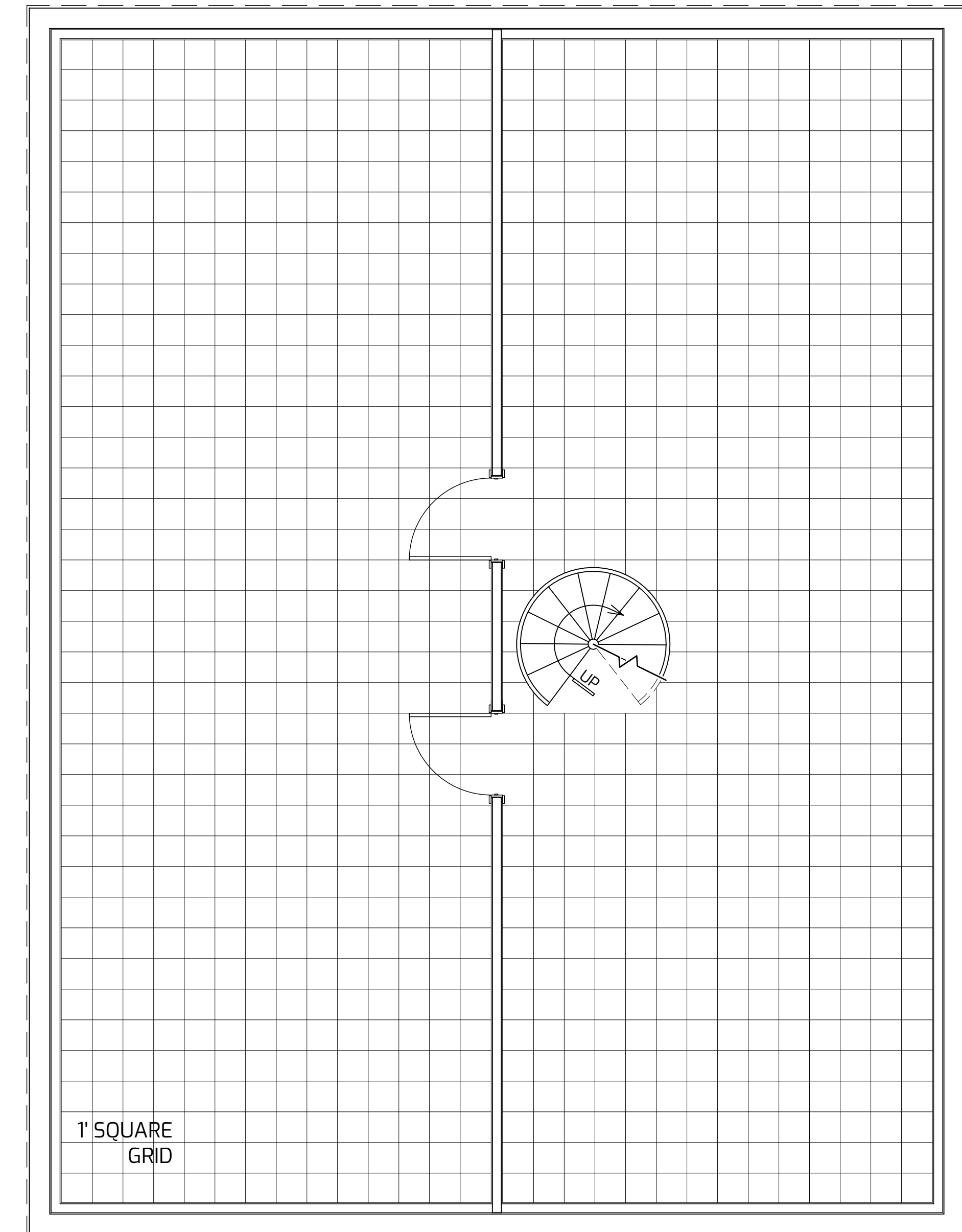

**BASEMENT DESIGN CRITERIA:**

- NO WINDOWS ON SIDE WALLS (GABLE ENDS ONLY).
- GARAGE DOOR MAX WIDTH 10' (DEPENDANT ON BASEMENT HEIGHT).
- BEDROOMS MUST BE ON GABLE ENDS FOR EGRESS PURPOSES.
- LENGTH OF GARAGE IS DETERMINED BY STAIR LOCATION.
- CENTER SUPPORT WALL REQUIRED TO SUPPORT MAIN LEVEL FLOOR JOISTS. CENTER SUPPORT WALL REMOVAL AVAILABLE WITH ADDITIONAL POST AND BEAM ENGINEERING.

**TRIO 120 SPIRAL STAIR W/ BASEMENT**

**SQUARE FOOTAGE**

MAIN LEVEL: 901 SQ.FT  
UPPER LEVEL: 457 SQ.FT  
BASEMENT: 1,077 SQ.FT  
TOTAL: 2,435 SQ.FT

DATE 01/2022

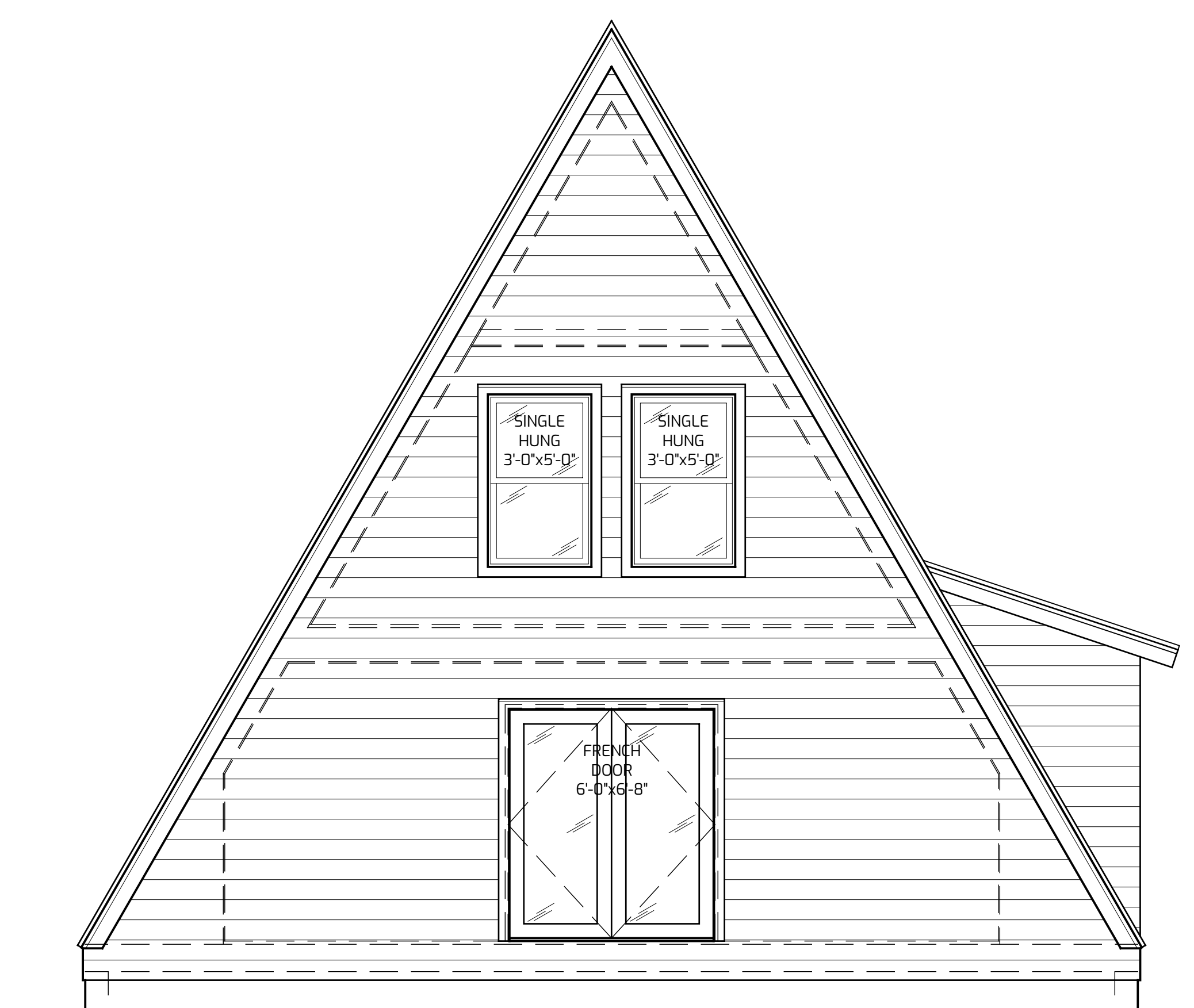
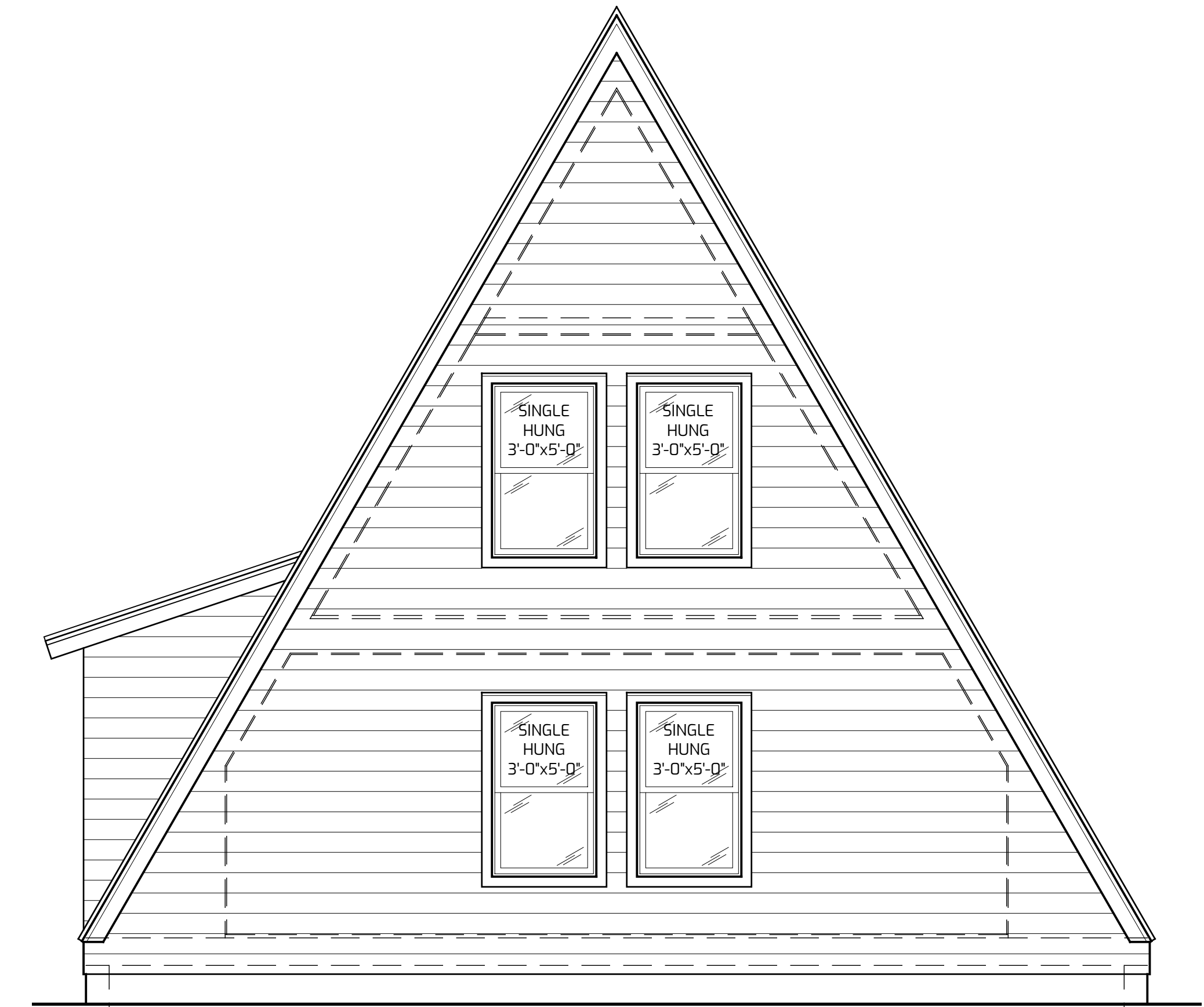
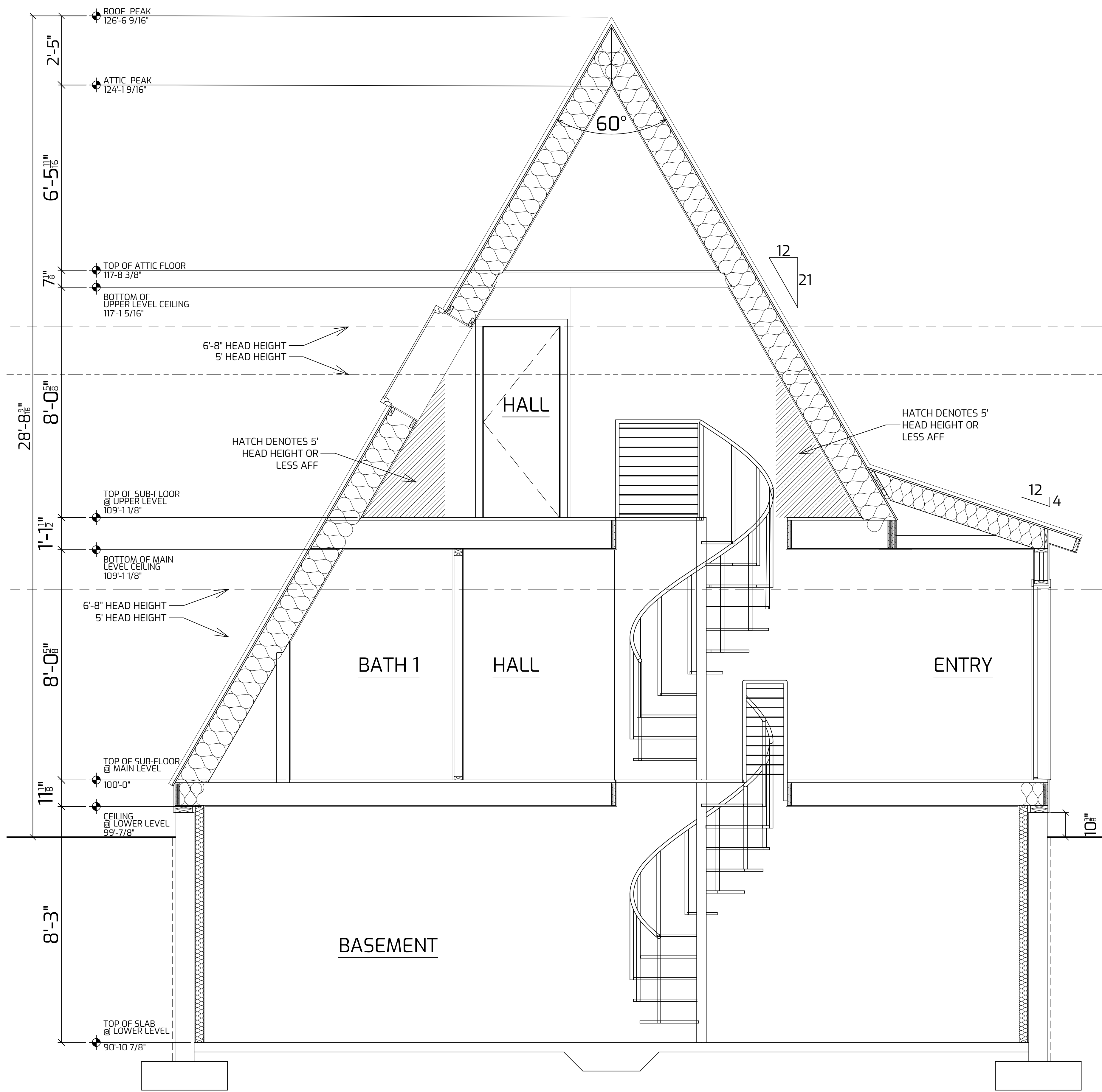

UPPER LEVEL FLOOR PLAN

NTS

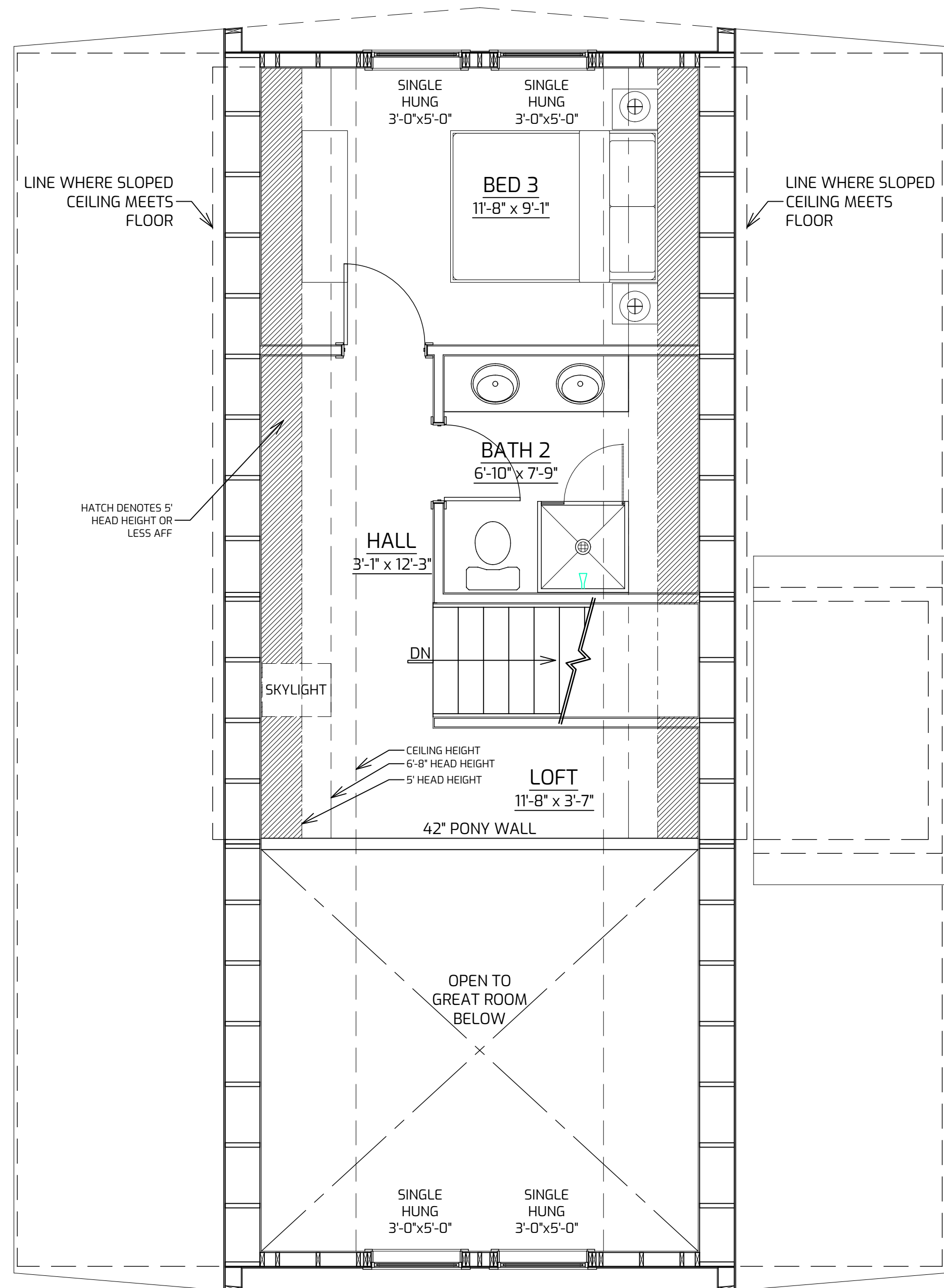

MAIN LEVEL FLOOR PLAN

NTS

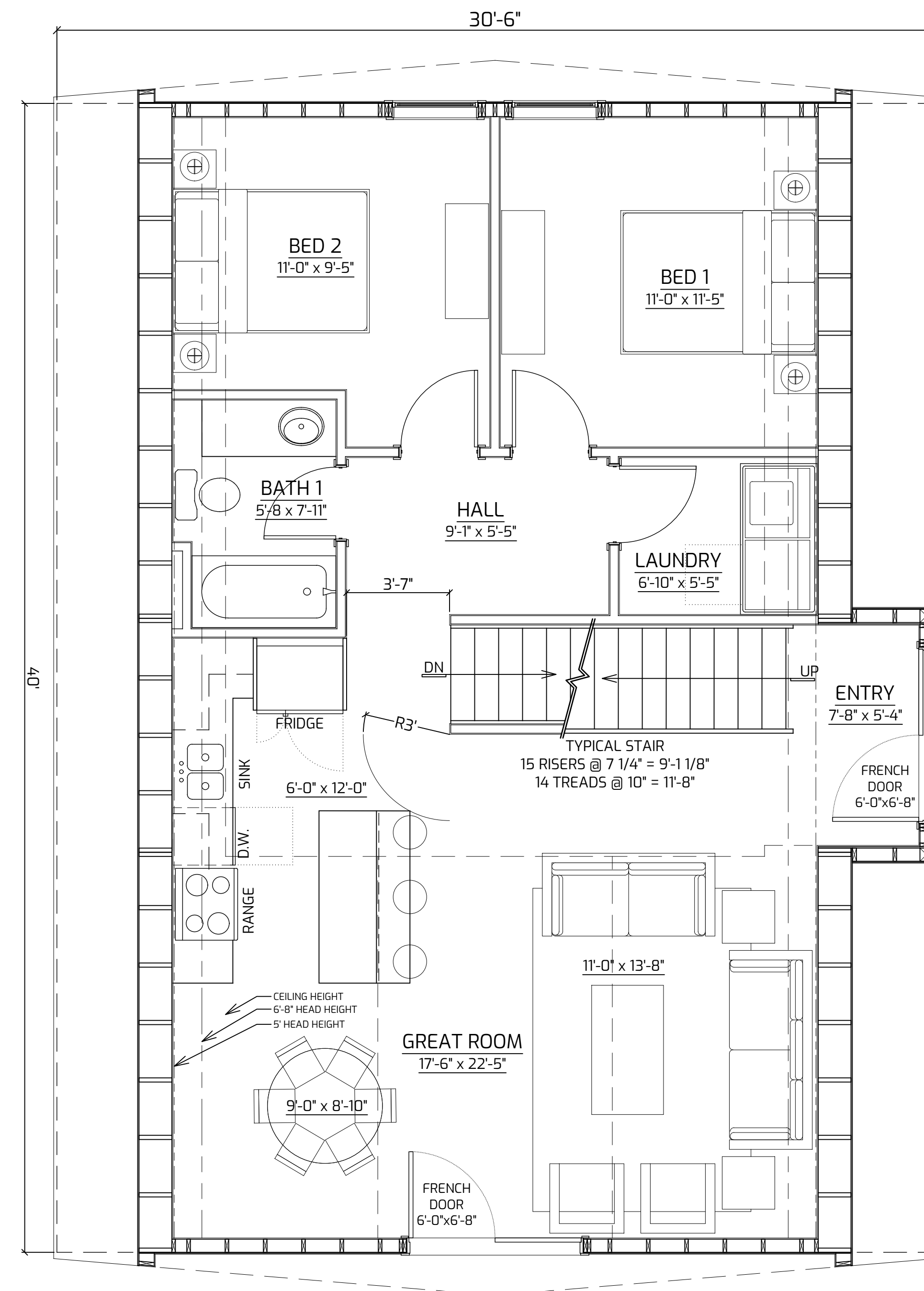

BASEMENT LEVEL FLOOR PLAN

SEE GRID FOR SCALE

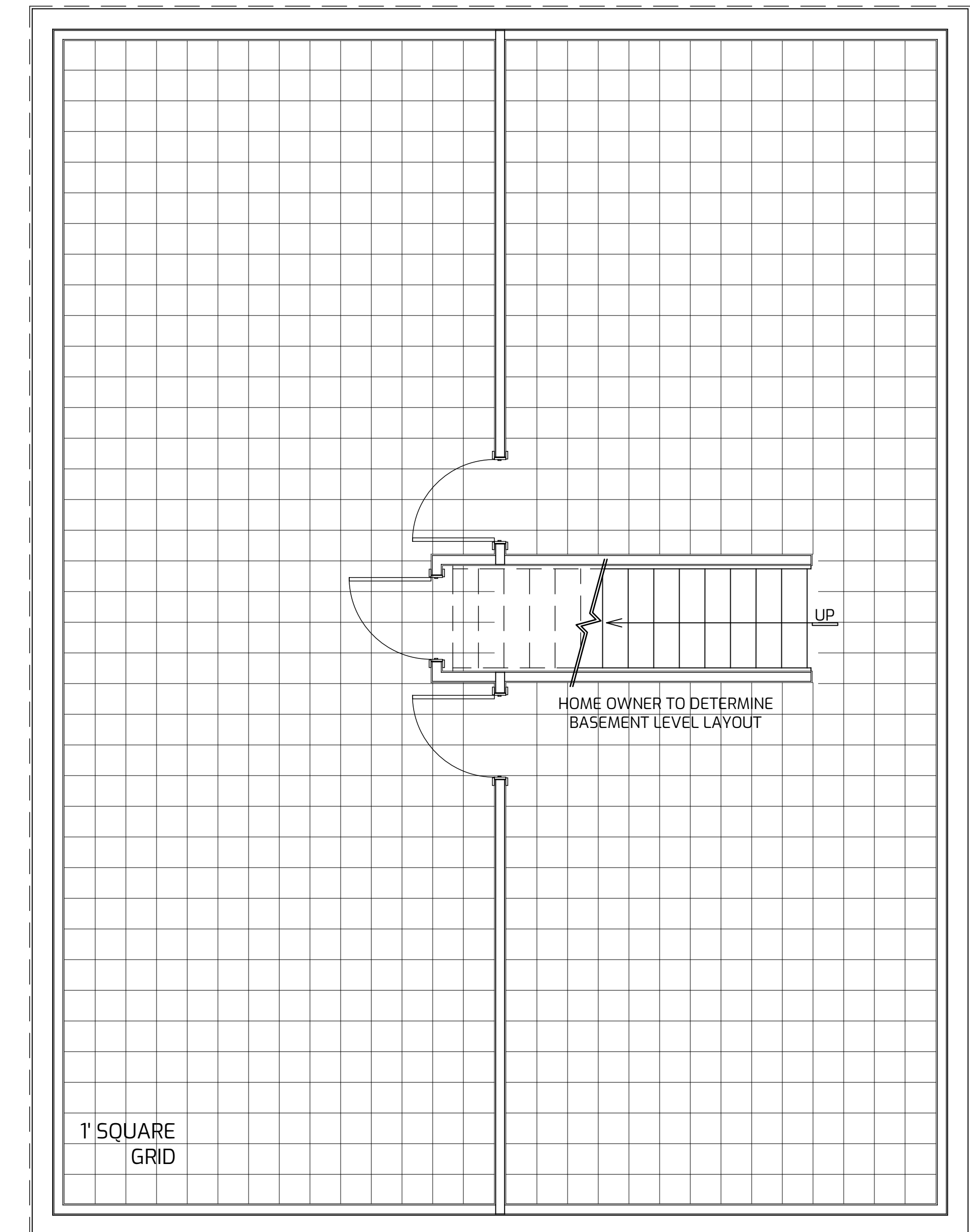

BASEMENT DESIGN CRITERIA:

- NO WINDOWS ON SIDE WALLS (GABLE ENDS ONLY).
- GARAGE DOOR MAX WIDTH 10' (DEPENDANT ON BASEMENT HEIGHT).
- BEDROOMS MUST BE ON GABLE ENDS FOR EGRESS PURPOSES.
- LENGTH OF GARAGE IS DETERMINED BY STAIR LOCATION.
- CENTER SUPPORT WALL REQUIRED TO SUPPORT MAIN LEVEL FLOOR JOISTS. CENTER SUPPORT WALL REMOVAL AVAILABLE WITH ADDITIONAL POST AND BEAM ENGINEERING.

TRIO 120 OPEN TO BELOW STRAIGHT STAIR W/ BASEMENT

SQUARE FOOTAGE

MAIN LEVEL: 901 SQ.FT

UPPER LEVEL: 457 SQ.FT

BASEMENT: 1,077 SQ.FT

TOTAL: 2,435 SQ.FT

DATE 01/2022

BUILDING CROSS SECTION

NTS

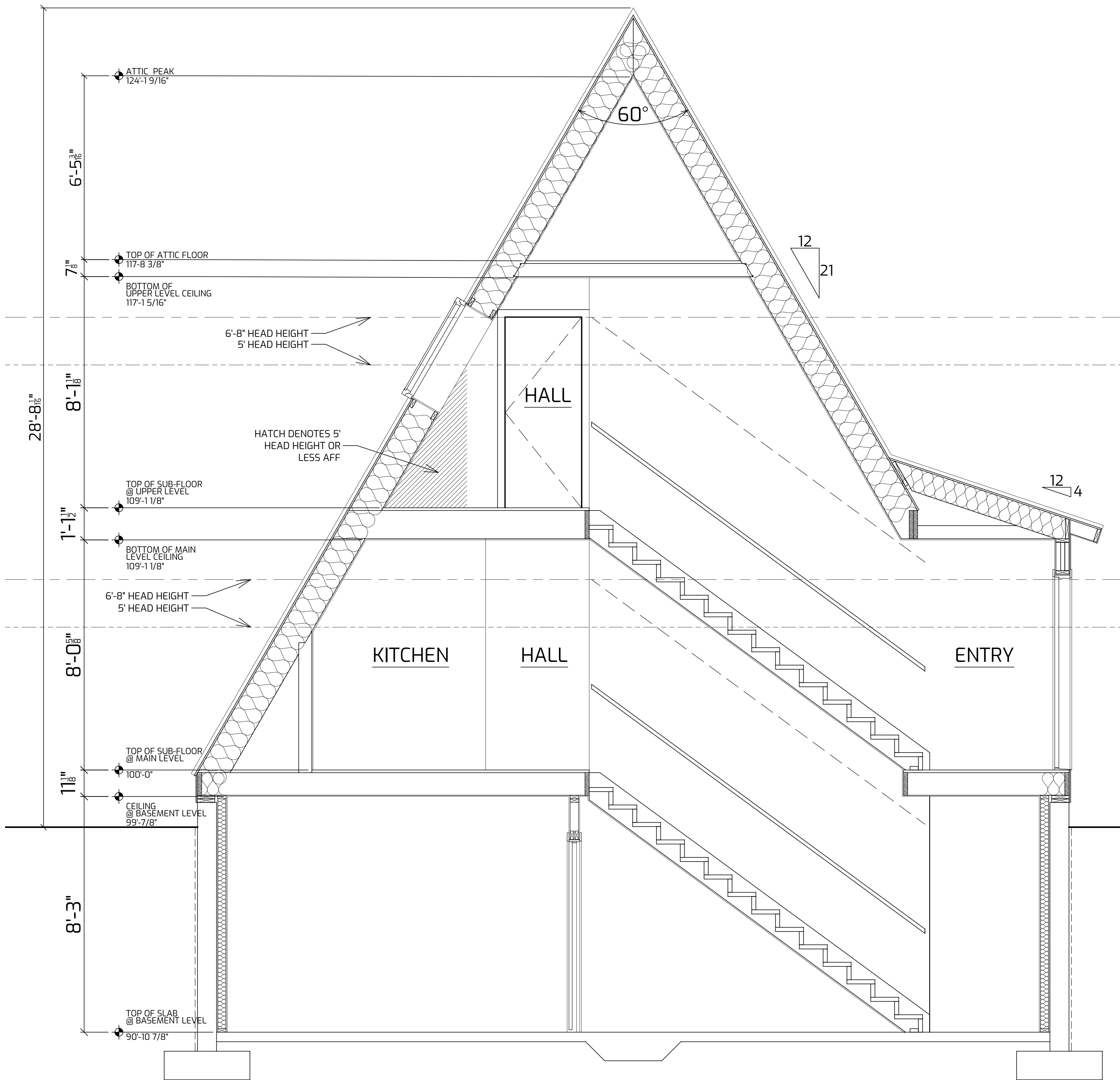

REAR ELEVATION

NTS

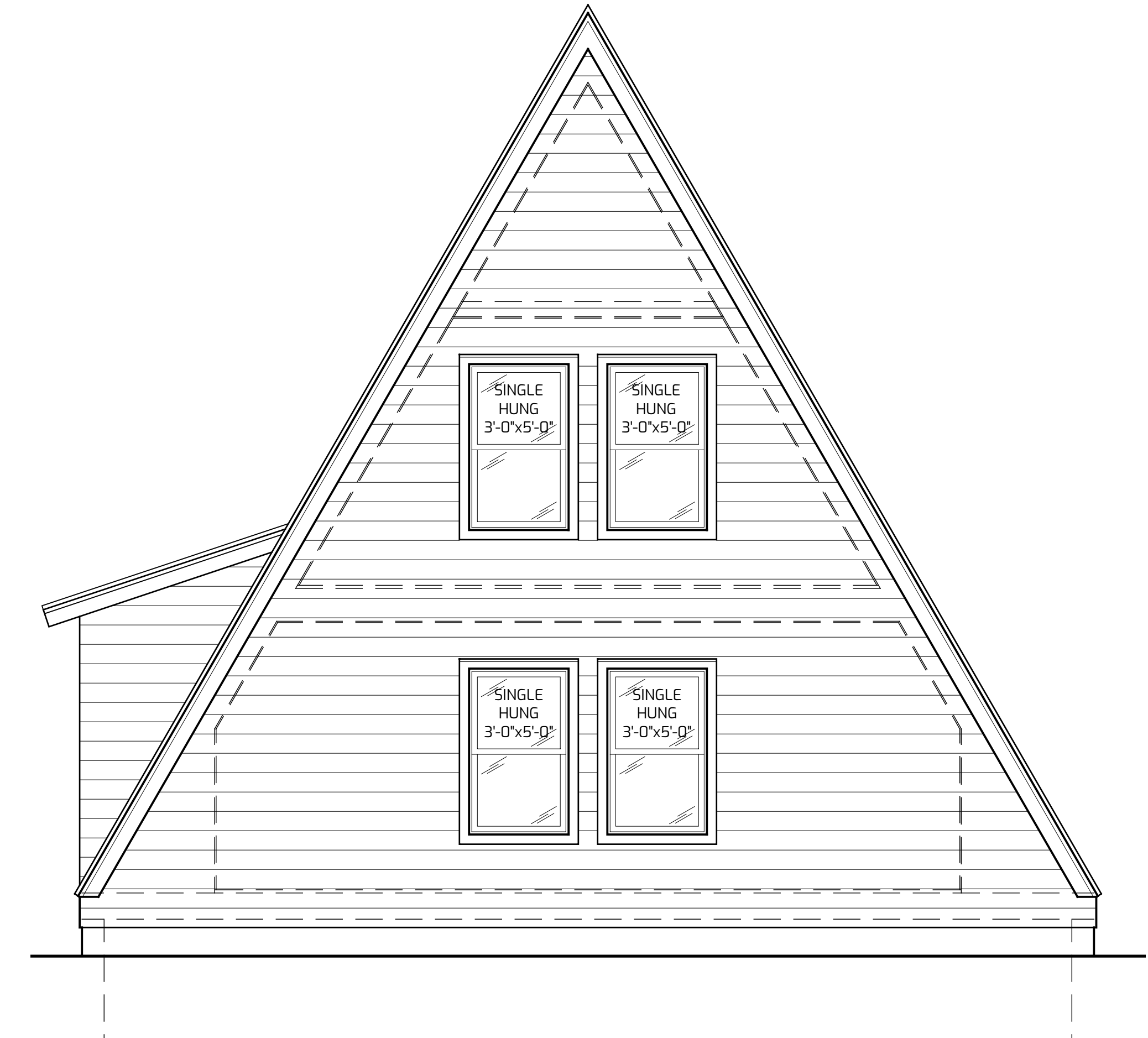

FRONT ELEVATION

NTS



THE GRAPHIC MATERIAL AND DESIGN SET FORTH HEREIN IS THE PROPERTY OF AVRAME U.S.A. ANY REPRODUCTION OR REUSE OF THE MATERIAL AND DESIGN CONTAINED HEREIN WITHOUT THE WRITTEN CONSENT OF AVRAME U.S.A. VIOLATORS WILL BE PROSECUTED TO THE FULLEST EXTENT OF THE LAW. COPYRIGHT © AVRAME U.S.A. ALL RIGHTS RESERVED.

**TRIO 120 OPEN TO BELOW STRAIGHT STAIR W/ BASEMENT**

SQUARE FOOTAGE

MAIN LEVEL: 901 SQ.FT  
UPPER LEVEL: 457 SQ.FT  
BASEMENT: 1,077 SQ.FT  
TOTAL: 2,435 SQ.FT

DATE 01/2022

UPPER LEVEL FLOOR PLAN  
SEE GRID FOR SCALE

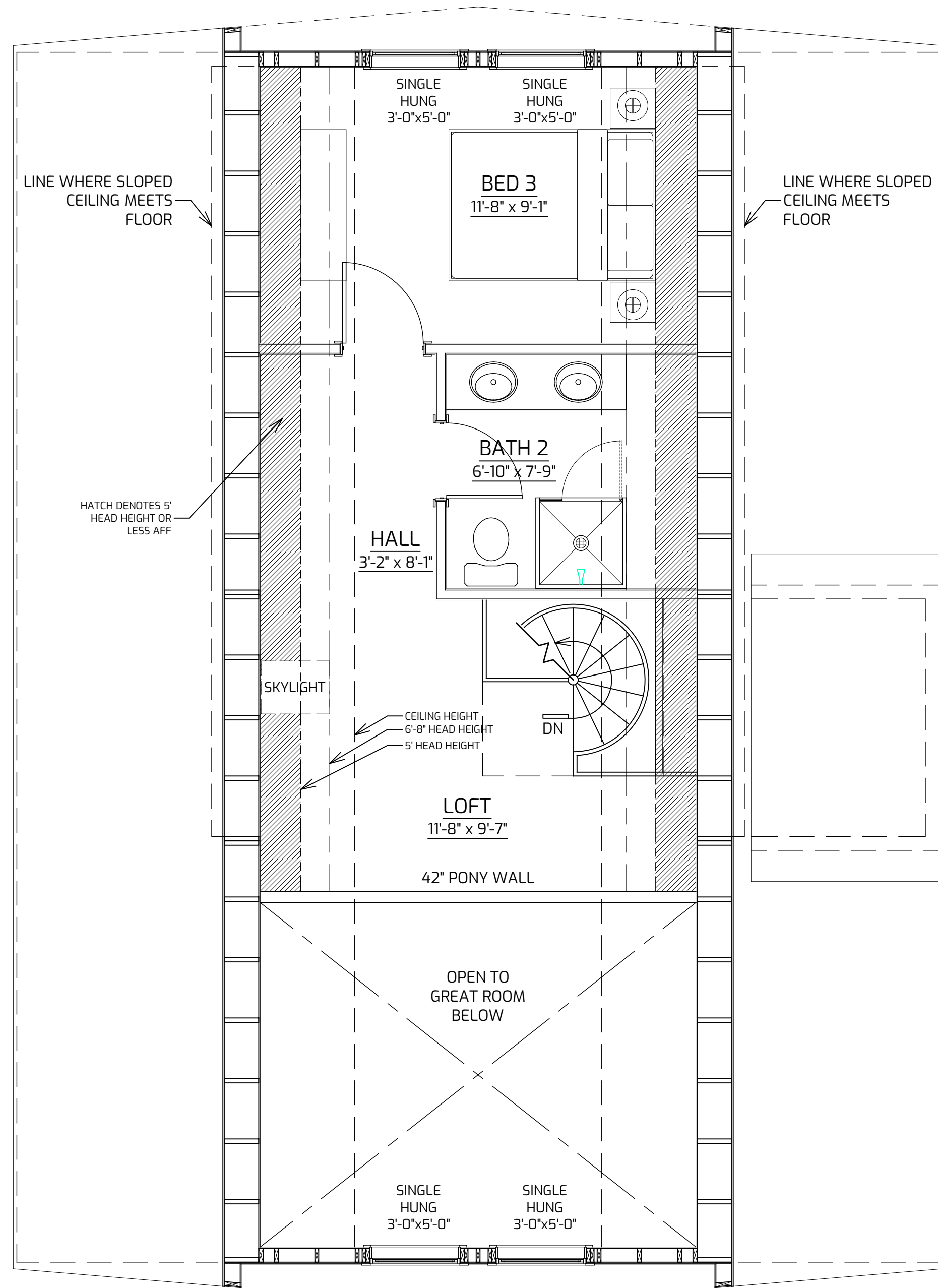

MAIN LEVEL FLOOR PLAN  
SEE GRID FOR SCALE

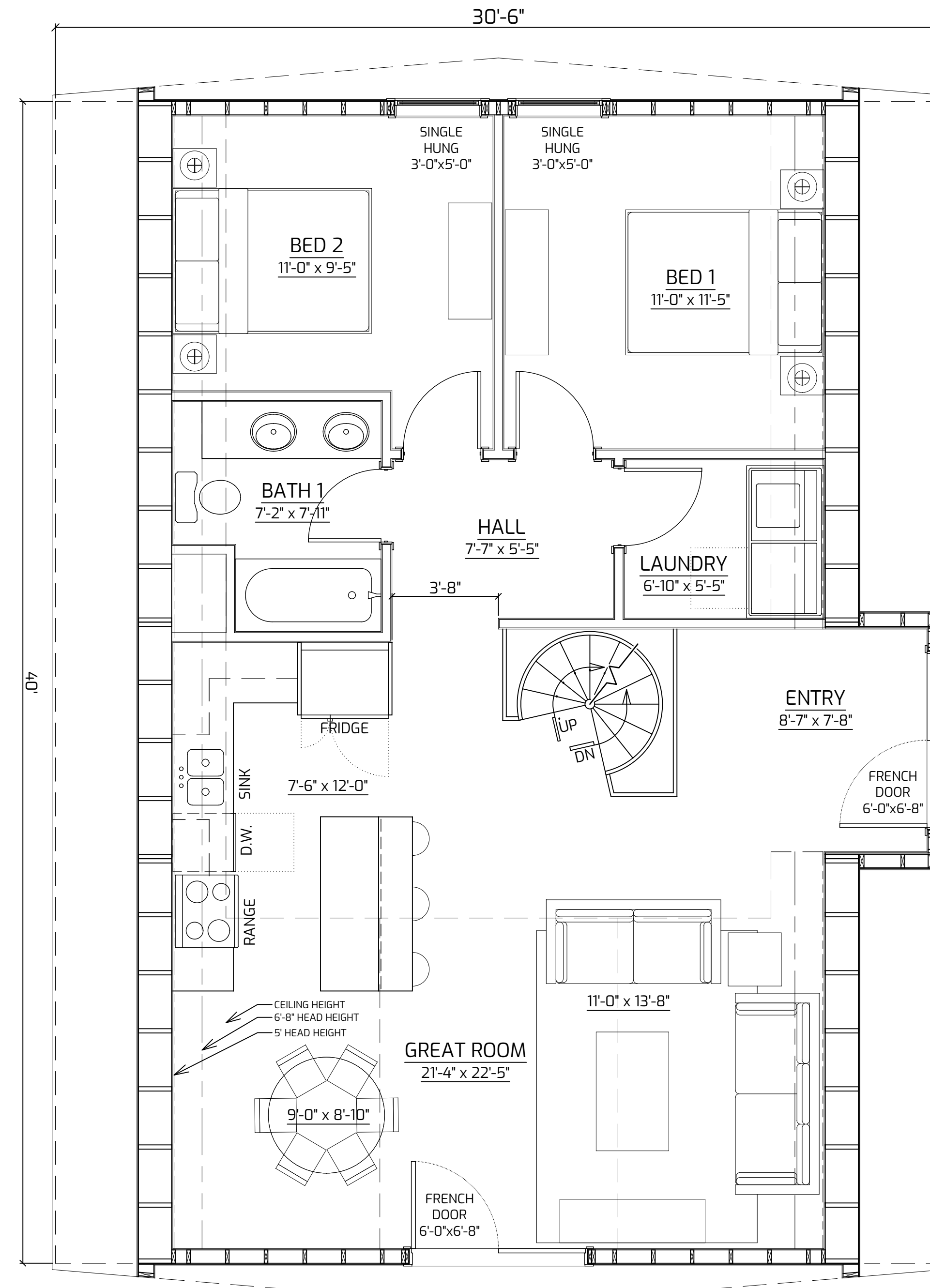

BASEMENT LEVEL FLOOR PLAN  
SEE GRID FOR SCALE

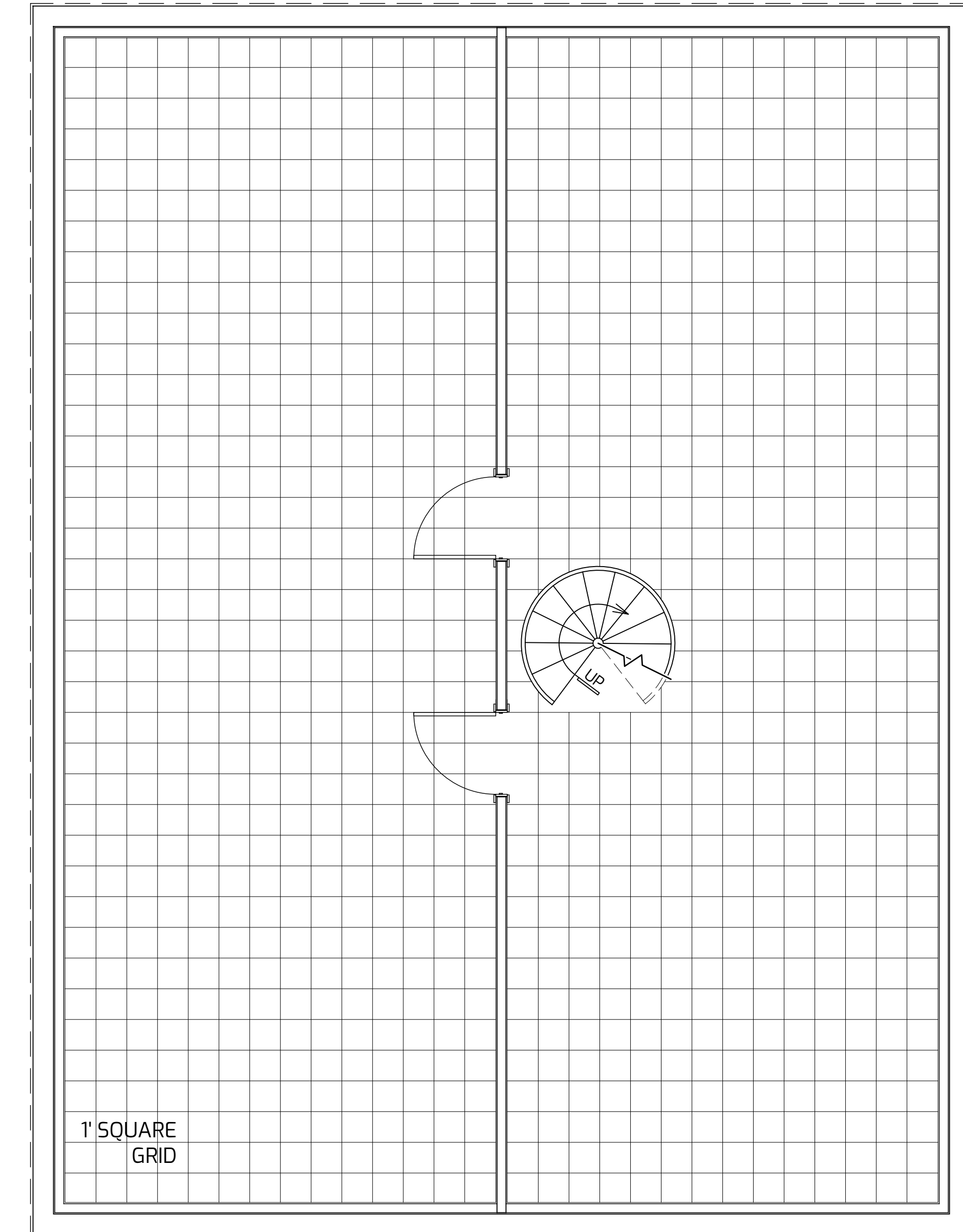

BASEMENT DESIGN CRITERIA:

- NO WINDOWS ON SIDE WALLS (GABLE ENDS ONLY).
- GARAGE DOOR MAX WIDTH 10' (DEPENDANT ON BASEMENT HEIGHT).
- BEDROOMS MUST BE ON GABLE ENDS FOR EGRESS PURPOSES.
- LENGTH OF GARAGE IS DETERMINED BY STAIR LOCATION.
- CENTER SUPPORT WALL REQUIRED TO SUPPORT MAIN LEVEL FLOOR JOISTS. CENTER SUPPORT WALL REMOVAL AVAILABLE WITH ADDITIONAL POST AND BEAM ENGINEERING.

TRIO 120 OPEN TO BELOW SPIRAL STAIR  
W/ BASEMENT

SQUARE FOOTAGE

MAIN LEVEL: 901 SQ.FT

UPPER LEVEL: 457 SQ.FT

BASEMENT: 1,077 SQ.FT

TOTAL: 2,435 SQ.FT

DATE 01/2022

**BUILDING CROSS SECTION**

NTS

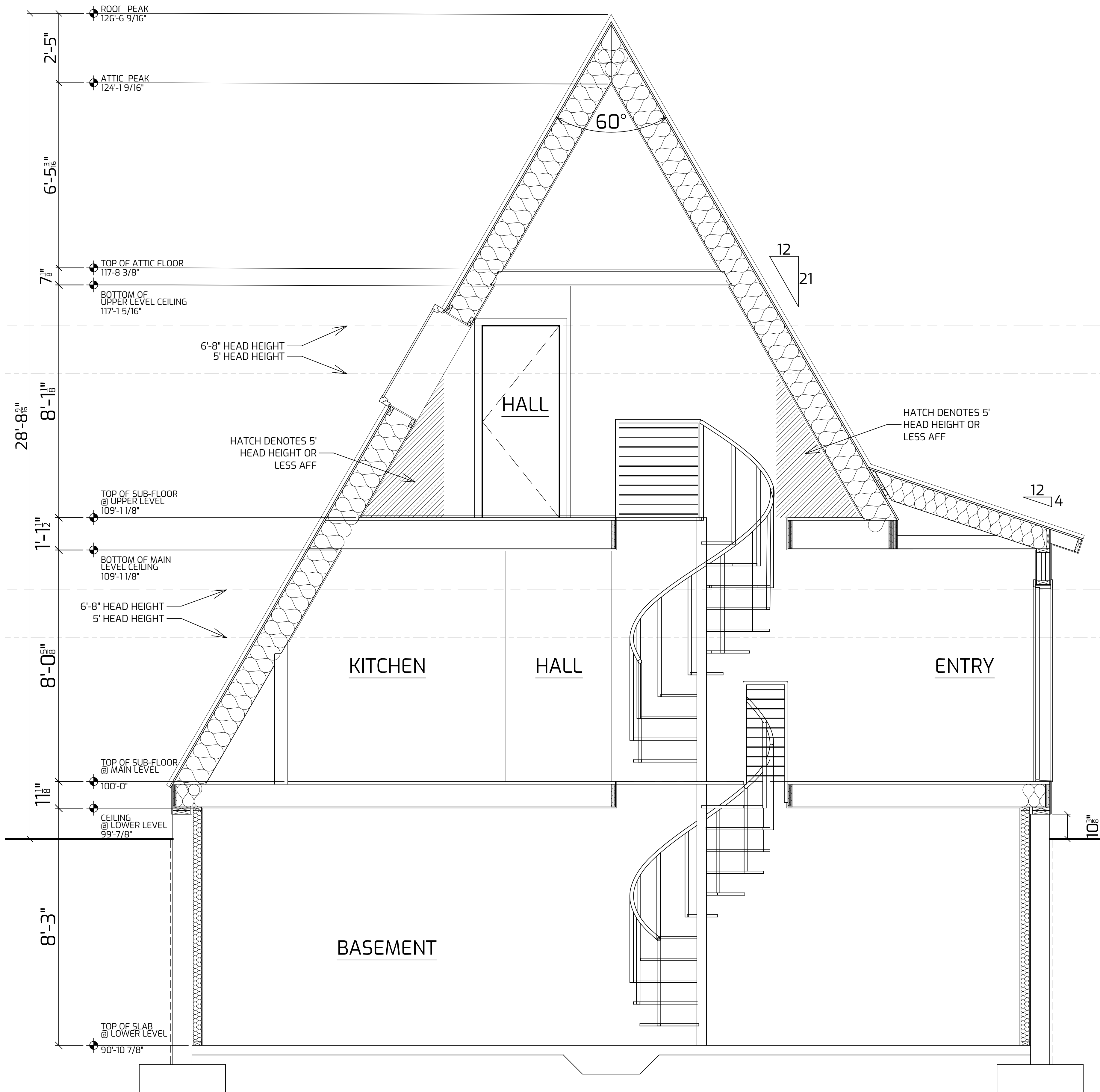

**REAR ELEVATION**

NTS

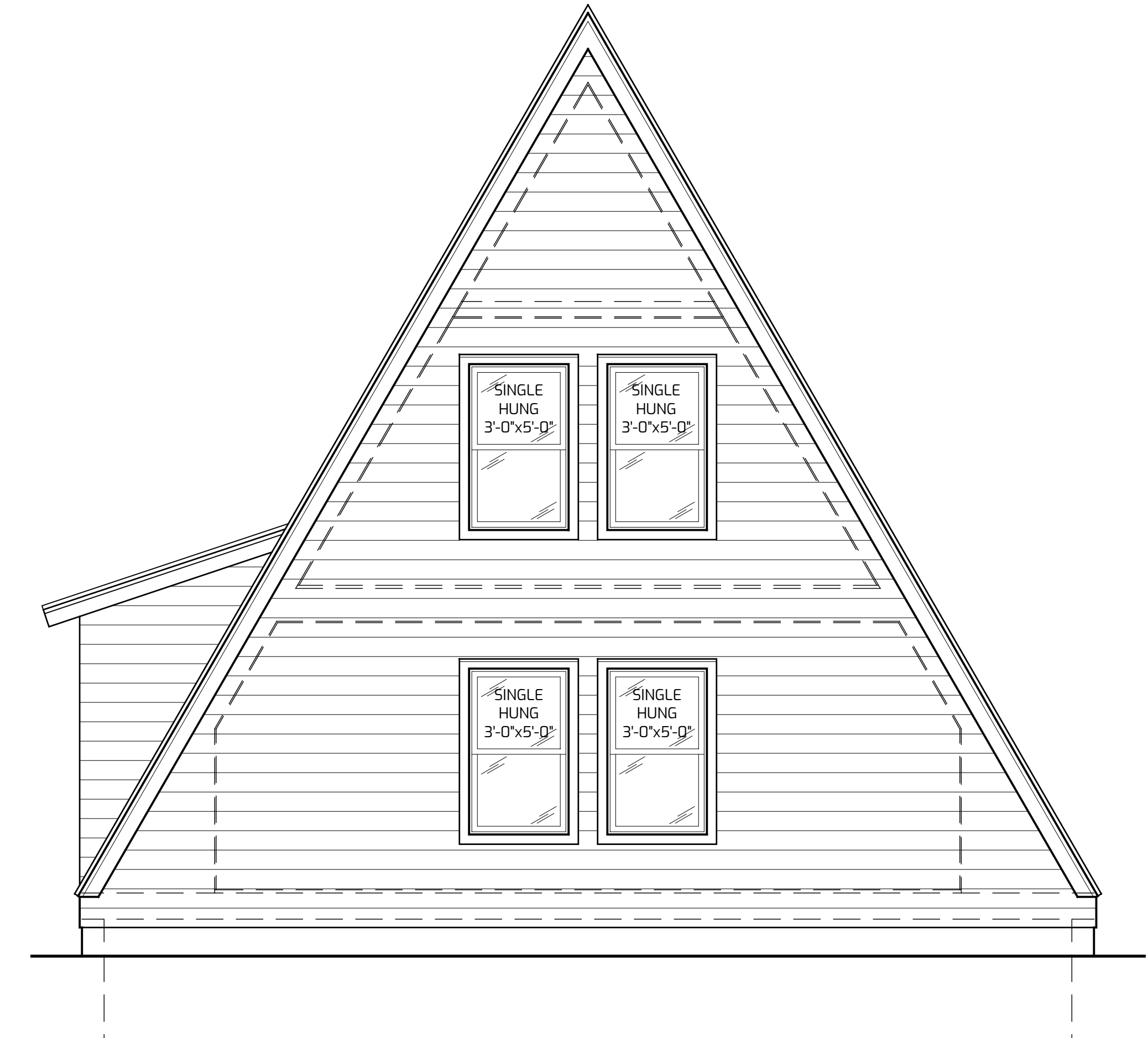

**FRONT ELEVATION**

NTS



THE GRAPHIC MATERIAL AND DESIGN SET FORTH HEREIN ARE THE PROPERTY OF AVRAME U.S.A. REPRODUCTION OR REUSE OF THE MATERIAL AND DESIGN CONTAINED HEREIN WITHOUT THE WRITTEN CONSENT OF AVRAME U.S.A. VIOLATORS WILL BE PROSECUTED TO THE FULLEST EXTENT OF THE LAW. COPYRIGHT © AVRAME U.S.A. ALL RIGHTS RESERVED.

**TRIO 120 OPEN TO BELOW SPIRAL STAIR W/ BASEMENT**

**SQUARE FOOTAGE**

MAIN LEVEL: 901 SQ.FT  
 UPPER LEVEL: 457 SQ.FT  
 BASEMENT: 1,077 SQ.FT  
 TOTAL: 2,435 SQ.FT

DATE 01/2022